

Translation of the Original operating instructions (EN)

APH 5020	Serial Nr. 11040831-
APH 5030	Serial Nr. 11052473-
APH 6020	Serial Nr. 11040481-
APH 6530	Serial Nr. 11052530-
APH 100-20	Serial Nr. 11040857-

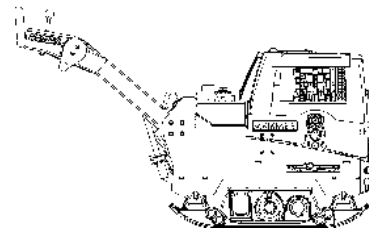



These instructions include:

- Safety regulations
- Operating instructions
- Maintenance instructions

These instructions have been prepared for operation on the construction site and for the maintenance engineer.

These instructions are intended to simplify operation of the machine and to avoid malfunctions through improper operation.

Observing the maintenance instructions will increase the reliability and service life of the machine when used on the construction site and reduce repair costs and downtimes.

Always keep these instructions at the place of use of the machine.

Only operate the machine as instructed and follow these instructions.

Do not fail to comply with the safety provisions, as well as the rules for safety and health protection at work («BGR 118 - Dealing with moving road construction machinery») of the German federation of institutions for statutory accident insurance and prevention (HVBG), as well as the applicable accident prevention regulations.

Also observe the corresponding rules and regulations valid in your country.

Ammann Verdichtung GmbH is not liable for the function of the machine when used in an improper manner and for other than the intended purpose.

Operating errors, improper maintenance and the use of incorrect operating materials are not covered by the warranty.

The above information does not extend the warranty and liability conditions of business of Ammann Verdichtung GmbH.

We reserve us the right to take changings due to technical development without announcement.

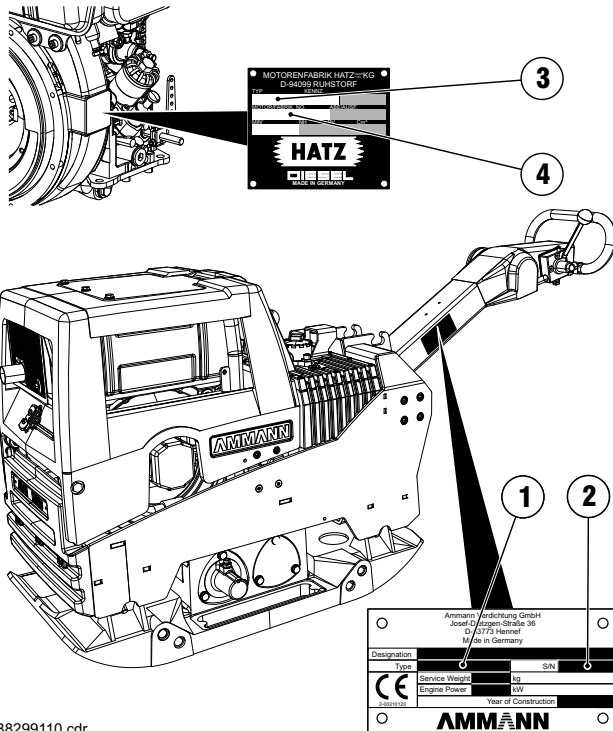

Please enter (data on machine type plate)

1. Mach.-type: _____

2. Mach.-No.: _____

3. Engine-type: _____

4. Engine-No.: _____

B8299110.cdr

Ammann Verdichtung GmbH

Josef-Dietzgen-Straße 36 • D-53773 Hennef

Tel.: +49 2242 8802-0 • FAX: +49 2242 8802-59

e-mail: info.avd@ammann-group.com

www.ammann-group.com

1. Safety regulations

This Ammann machine has been built according to the state of the art in compliance with the pertinent rules. Nevertheless, these machines can still constitute a hazard to persons and property if:

- not used for the intended purpose,
- not operated by suitably qualified and instructed personnel,
- modified or converted in an improper manner,
- the pertinent safety regulations are not observed

For this reason, any person entrusted with the operation, maintenance or repair of the machine is obliged to read and follow the operating instructions and particularly to observe the safety regulations. If necessary, it must be confirmed by the signature of the company using the machine.

Furthermore, the following must be made known and observed:

- pertinent regulations for the prevention of accidents,
- generally recognised safety rules,
- country-specific regulations

Normal use

The machine is suitable for all compaction jobs in civil works and road construction. All ground materials such as sand, gravel, sludge, crushed stone, asphalt and composite sett paving can be compacted.

Improper use

The machine can constitute hazards if not used by instructed personnel or for other than the intended purpose.

Weighing down and riding on the machine is forbidden.

The machine must not be used on slopes with a gradient of more than 25°.

Do not use the machine on hard concrete, set asphaltic surfaces, highly frozen or unstable surfaces.

Who is allowed to operate the machine?

Only suitable qualified, instructed and authorised persons over 18 years of age may operate the machine.

In variance from this, minors can be employed, as long as it is necessary to their training objective and their protection is assured by a supervisor.

Persons under the influence of alcohol, medication or drugs must not operate, maintain or repair the machine.

Maintenance and repairs, in particular of hydraulic systems and electronic components require special knowledge and must be carried out only by skilled persons (mechanics specialising in construction and agricultural machinery).

Conversions and modifications to the machine

Unauthorized modifications and conversion of the machine are not permitted for safety reasons.

Spare parts and special equipment not delivered by us are also not approved by us. The installation and/or the use of such parts can also have a detrimental effect on the operating safety.

The manufacturer disclaims all liability for any damage resulting from the use of non-original parts or special equipment.

Safety information in the operating instructions

The following signs and designations are used in the manual to designate instructions of particular importance:



Important

Refers to special information on how to use the machine most efficiently.



Attention

Refers to special information and/or orders and prohibitions directed towards preventing damage



Danger

Refers to orders and prohibitions designed to prevent injury or extensive damage.



Environment

Information on safe and environmentally-friendly disposal of operating and ancillary agents as well

Transporting the machine

Always shut off the motor when loading and transporting.

Only load and transport the machine as specified in the operating instructions.

Only use suitable means of transport and hoisting with sufficient loading capacity!

Attach suitable slinging means to the points of attachment provided.

Secure the machine to prevent it from tilting or slipping.

It is highly dangerous to walk or stand under suspended loads.

Secure the machine on transport vehicles to prevent it from rolling, slipping and tilting.

Starting the machine

Prior to starting

Familiarise yourself with the operating and control elements and the mode of operation of the machine and the working environment. This includes, e.g. obstacles in the working area, loading capacity of the ground and the necessary safety provisions.

Use personal protective equipment (safety footwear, hearing protectors, etc.).

Check to ensure that all safety devices are firmly in place.

Do not start the machine if instruments or control devices are faulty.

Starting

For machines with handstart, only use the safety cranks tested by the manufacturer, and precisely follow the operating instructions of the motor manufacturer.

To crank-start diesel motors; Important is the correct position to the motor and the correct hand position on the crank.

The handcrank must be turned with maximum force until the motor starts, otherwise the crank can rebound.

Precisely follow the starting and stopping procedures specified in the operating instructions and observe indicator lights.

Only start and operate machines with an electrical starter from the instrument panel.

Starting and operation of the machine in potentially explosives atmospheres is forbidden!

Starting with battery junction cables

Connect «positive» to «positive» and «negative» to «negative» (earthing lead). Always connect the earthing lead last and disconnect first! Incorrect connection will cause serious damage to the electrical system.

Starting in enclosed spaces, tunnels, mines or deep ditches

Engine exhaust gas are highly dangerous!

For this reason, when operating the machine in enclosed spaces, tunnels, mines or deep ditches, it is important to ensure that there is sufficient air to breath (see UVV „Construction work“, VBG 37, paragraphs 40 and 41).

Machine control

Operating devices which adjust themselves automatically when released in normal use, must not be locked.

Check protective devices and brakes for proper functioning prior to operation.

When reversing, particularly on the edges and banks of ditches, as well as in front of obstacles, the machine operator cannot fall or be crushed.

Always keep a safe distance away from the edges and banks of ditches and refrain from any actions which could cause the machine to topple over!

Always control the machine, so that hand injuries through hard objects are avoided!

Always ascend slopes carefully in a direct path.

Reverse up steep slopes to prevent the machine from toppling over on to the machine operator.

If faults on the safety devices or other faults detrimental to the safe operation of the machine are noticed, operation of the machine must be stopped immediately and the faults remedied.

When undertaking compaction work in the vicinity of buildings or above pipelines and similar, check the effect of the vibrations on the buildings and pipes and stop compaction work if necessary.

Parking the machine

Park the machine on a firm and level surface.

Shutdown the drive and secure it to prevent accidental movement and unauthorised use. If available, close the fuel valve. Do not place or store equipment with integrated moving gear on the chassis. The moving device is intended only for transportation purposes.

Filling petrol

Only fill petrol by switched-off motor.

No open fire, do not smoke.

Do not spill any fuel, collect discharging fuel in a suitable container, prevent fuel from seeking into the soil.

Ensure that the filler cap is tight.

Leaky fuel tanks constitute an explosion hazard and must therefore be replaced immediately.

Maintenance and repairs

Observe the maintenance, inspection and adjustments and intervals specified in the operating instructions, as well as the information for part replacement.

Maintenance work must be undertaken only by qualified and authorised persons.

Maintenance and repairs only by switched-off drive.

Only carry out maintenance and repairs when the machine is parked on a firm and even surface and is secured to prevent it from rolling.

When changing larger assemblies and individual components, only use suitable and perfectly functioning hoistings and lifting gears with suitable loading capacity. Attach and secure parts on hoisting carefully!

Spare parts must comply with the technical requirements of the manufacturer. Therefore only use original spare parts.

Hydraulic lines must previously be rendered pressureless, before working on them. Hydraulic oil discharging under pressure can cause serious injuries.

Work on hydraulic devices must be undertaken only by persons with a special knowledge of hydraulics and the necessary experience!

Do not adjust pressure relief valves.

Drain hydraulic oil at operating temperature—caution risk of scalding!

Collect discharging hydraulic oil and dispose of the same in an environmentally-friendly manner.

Do not start the motor when hydraulic oil has been drained off.

After completing all work (by pressureless system), inspect all connections and bolted connections for leaks.

Inspect all hoses and bolted connections for leaks at regular intervals and externally visible damage! Rectify any damage immediately.

Replace externally damaged hydraulic hoses at regular intervals (depending on time used), even when no safety-relevant faults are visible.

Before working on the electrical system of the machine, disconnect the battery and insulate by covering or remove.

Inspect the electrical equipment of the machine at regular intervals. Faults such as loose connections, worn or scorched cables must be immediately eliminated.

During transport, secure the battery to prevent it from tilting, short-circuit, slipping and damage.

Dispose of used batteries in a proper manner.

Do not place any tools on the battery.

Handling acid-batteries

Transport filled batteries upright to prevent acid spillage.

Keep away from sparks, open fire and other sources of ignition.

Avoid contact of acid with skin and clothing. In case of contact, wash off acid immediately with clear water and go to medical institution.

Properly refit and inspect all protective devices after maintenance and repairs.

Disposal of the machine after finish of its service life

At disposal of the machine after finish of its service life, the owner is obliged to comply with national regulations and laws on wastes and protection of environment. Therefore we recommend in such cases to contact the following:

- professional specialized companies engaged in such activities and having the relevant certificate
- the manufacturers or contracting service organizations authorized by him.

The manufacturer is not responsible for damages to health of owners neither for damages to the environment in events of failing to comply with above mentioned hygienic and ecological principles.

Testing

Road rollers, trench rollers and vibrating plates must be tested for safety by an expert depending on the particular application and operating conditions as required, however at least once a year.

2. Technical data

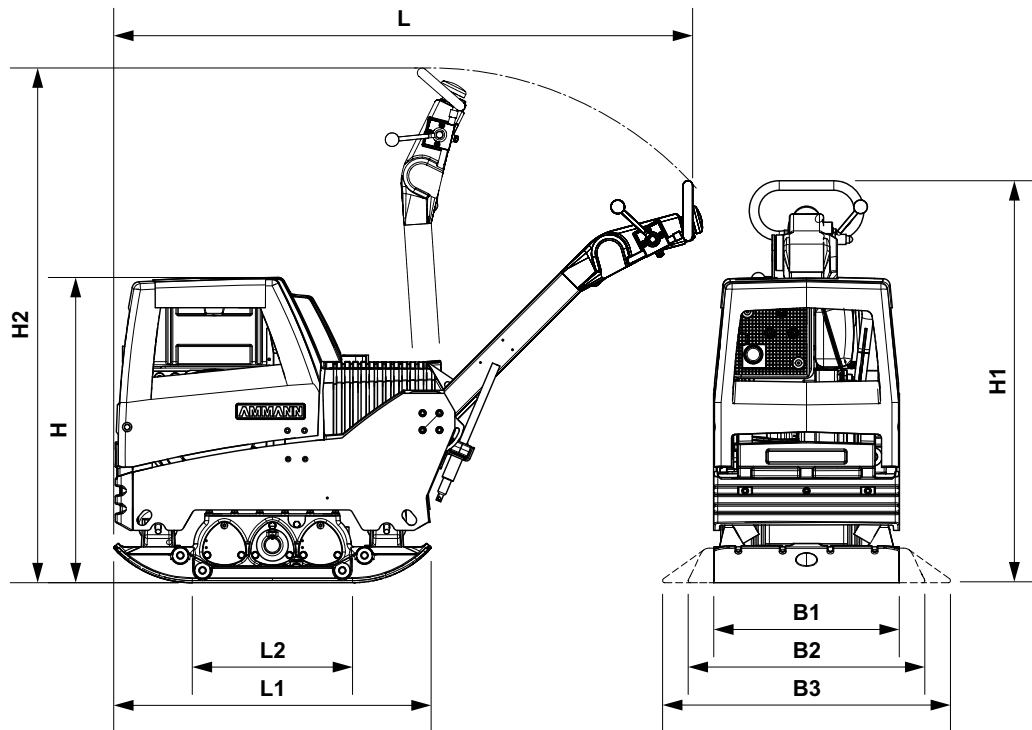

	APH 5020	APH 5030	APH 6020	APH 6530	APH 100-20
1. Dimensions					
L	1600 mm		1840 mm		1965 mm
L1	900 mm		930 mm		1070 mm
L2	450 mm		470 mm		520 mm
H	775 mm		870 mm		900 mm
H1	ca. 1000 mm				
H2	ca. 1500 mm				
Working width, base unit	450 mm		550 mm		650 mm
w. mount. brackets 75 / 150 mm	600 / 750 mm		700 / 850 mm		800 / 950 mm
2. Weights					
Base unit	367 kg	368 kg	482 kg	491 kg	675 kg
w. mount. brackets 75 mm	388 kg	389 kg	506 kg	515 kg	704 kg
w. mount. brackets 150 mm	400 kg	402 kg	518 kg	527 kg	727 kg
Electrical starter	+ 16 kg	+ 16 kg	+ 18 kg	+ 18 kg	Standard
Electr. dead man's control	+ 17 kg	+ 17 kg	+ 19 kg	+ 19 kg	+ 2 kg
ACEecon	+ 17 kg	+ 17 kg	+ 18 kg	+ 18 kg	- 2 kg
3. Drive					
Engine	HATZ 1D50 S		HATZ 1D81 S		HATZ 1D90 S
Type	1-cylinder, four-stroke diesel				
Power output	7,0 kW (9,5 hp)		10,1 kW (13,7 hp)		10,9 kW (14,8 hp)
Speed	3100 1/min		3000 1/min	3000 1/min	3000 1/min
Cooling	Air				
Fuel capacity	5 l		7 l		10 l
Fuel consumption	1,7 l/h		2,5 l/h		
max. sloping position	30°				

2. Technical data

	APH 5020	APH 5030	APH 6020	APH 6530	APH 100-20
max. grade ability	36 %				
Drive	via centrifugal clutch and hydr. power transmission				hydraulic
Control (forward/reverse)	hydraulic				
4. Operating speed					
	0 - 22 m/min	0 - 28 m/min	0 - 32 m/min	0 - 28 m/min	
5. Vibration					
Centrifugal power	50 kN	60 kN	65 kN	80 kN	
Vibration frequency	65 Hz	69 Hz	55 Hz	40 Hz	
6. Superficial power					
Base unit	594 m ² /h	925 m ² /h	1056 m ² /h	1090 m ² /h	
w. mount. brackets 75 / 150 mm	792 / 990 m ² /h	1260 / 1430 m ² /h	1344 / 1632 m ² /h	1350 / 1600 m ² /h	
7. Special equipment					
Vulkollan plate	O		O	—	
Mounting brackets 75 mm	O		O	O	
Mounting brackets 150 mm	O		O	O	
Protecting cover	O		O	O	
Operating hours meter	O		O	O	
Electrical starter	O		O	S	
Emergency stop switch	O		O	S	
ACEecon-system	O		O	O	
O = Option S = Serial — = Not available					
8. Noise and vibration data					
The following noise and vibration data according to EC Machinery Directive in the version (2006/42/EC), was determined, taking into account the following standards and directives. In operational use, values can deviate depending on the prevailing conditions.					
8.1 Noise data³⁾					
The noise data specified in Appendix 1, sub-clause 1.7.4.u of the EC Machinery Directive is for:					
Sound pressure level at the workplace L _{PA}	92,0 dB		95,0 dB	93,3 dB	
Measured sound power level L _{WA,m}	106 dB		107 dB		
Guaranteed sound power level L _{WA,g}	108 dB		109 dB		
The noise values were determined, taking into account the following directives and standards: Directive 2000/14/EC / EN ISO 3744 / EN 500-4					
8.2 Vibration data					
Hand/arm vibration values according to Appendix 1, sub-clause 3.6.3.1 of the EC Machinery Directive:					
Total vibration value of the acceleration a _{hv}	4.9 m/s ²	4.9 m/s ²	5.8 m/s ²	6.4 m/s ²	8.4 m/s ²
Uncertainty K	1.0 m/s ²				
The acceleration value was determined, taking into account the following directives and standards: EN 500-4 / DIN EN ISO 5349					



³⁾As the permissible rating sound level of 85 dB (A) can be exceeded by this machine, operators must wear hearing protectors.

3. Operation

3.1 Description

The APH 5020/5030/6020/6530/100-20 are reversible vibrating plates operating on the basis of the twin-shaft resp. three-shaft vibration system principle. The Engine drives the exciter on the baseplate via hydraulic components.

The exciter produces the vibration required for compaction owing to the incorporated out-of-balance weights.

The machine is guided at the tow-bar grip. It is operated with the operating controls on the tow-bar.

The APH 5020/5030/6020/6530/100-20 are suitable for all heavy compaction work in the fields of civil Engineering and road construction.

It can be used to compact all ground materials such as sand, gravel, slag, crushed stone, asphalt and composite sett paving.



Take great care on downslopes. The machine could slip down owing to loose material or if the surface is slippery.

Do not work on hard concrete or set asphalt surfacing.

3.1.1 Overview of components

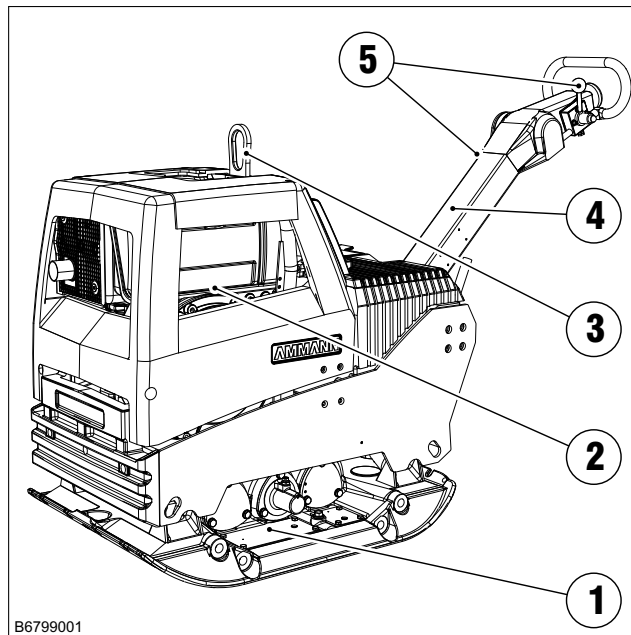

- 1 Baseplate with exciter
- 2 Engine
- 3 Central-point suspension
- 4 Tow-bar
- 5 Operating controls / tow-bar

3.2 Operating controls on the tow-bar

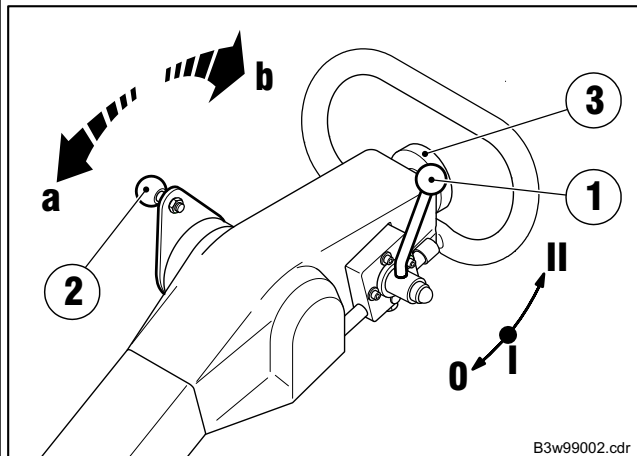

1 Engine speed control lever

- 0 Engine stop
- I Idle (detent position)
- II Full load

The Engine speed can be adjusted steplessly with the control lever. At minimum Engine speed (I), the drive to the exciter is disconnected at the centrifugal clutch and the Engine idles.

The centrifugal clutch engages when the control lever is moved approximately $\frac{1}{4}$ of its adjustment travel.



The Engine speed should always be well below or well above the engaging speed of the centrifugal clutch, otherwise, the clutch linings will wear very quickly or could even be destroyed.

2 Drive lever

- a Forward
- b Reverse

The drive lever serves to adjust the movements in the exciter and therefore provides a stepless control

- of the travel direction forwards (a) / backwards (b)
- of the speed

3 Emergency stop connection¹⁾

The emergency stop switch serves to immediately halt the machine in emergency situations.

Once the switch knob is pressed the power transmission is interrupted and the machine itself stops though the Engine continues to run.

Following the pressing of the switch during operation:

- The switch is released by withdrawing it.
- Normal operation can then be immediately resumed. (The travel direction and speed do not need to be reselected).



Engine start is possible with the switch depressed.

¹⁾ APH 5020/5030/6020/6530: Special equipment

3.3 Before operation



Danger

Use personal protective equipment (in particular hearing protectors and safety shoes).

Observe the safety conditions.

Observe the operation and maintenance instructions.

Read the Engine operating instructions. Observe the Important on safety, operation and maintenance contained in them.

- Stand the machine on an even surface.
- Check
 - the Engine oil level
 - the hydraulic oil level
 - the fuel supply
 - that screw connections are secure
 - the condition of the Engine and the machine.
- Top-up any missing lubrication in accordance with the lubrication table.

3.4 Adjusting / locking the tow-bar

3.4.1 Adjusting the tow-bar

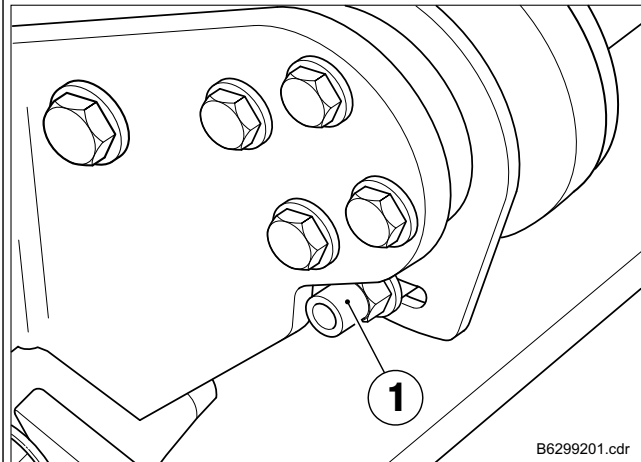

B6299201.cdr

The two stop bushes (1) on the tow-bar element can be adjusted to any position in order to achieve the best working height on the tow-bar grip.

3.4.2 Locking the tow-bar

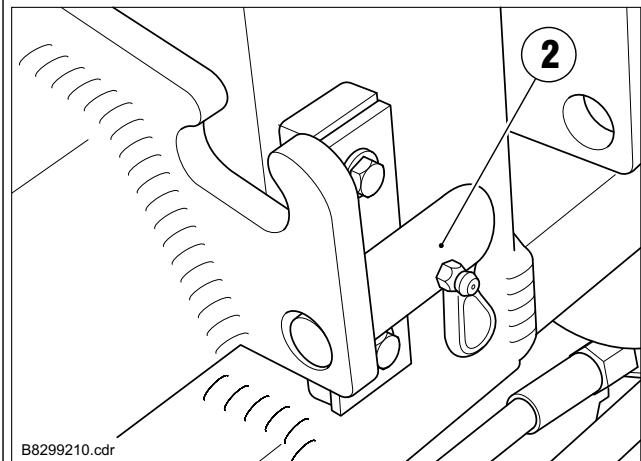

B8299210.cdr

The handle can be fixed in upright (2) position.

The tow-bar lock makes it easier to handle the machine when loading it.



Attention

To prevent deflection, the tow-bar must not be locked during normal operation.

3. Operation

3.5 Engine operation

3.5.1 Engine control – APH 100-20

The machines are fitted with an engine control.

This includes

- Starter safeguard lock
- Electronic oil deficiency cut-off in the event of an oil deficiency, the engine cuts out. In this case
 - Top up oil or clear fault
 - Start the engine
- Protection against exhaustive discharge when ignition is left switched on. When the engine is switched on, the control switches off all consumers after 2 minutes. In this case
 - Turn ignition key to «0».
- Start engine as described.

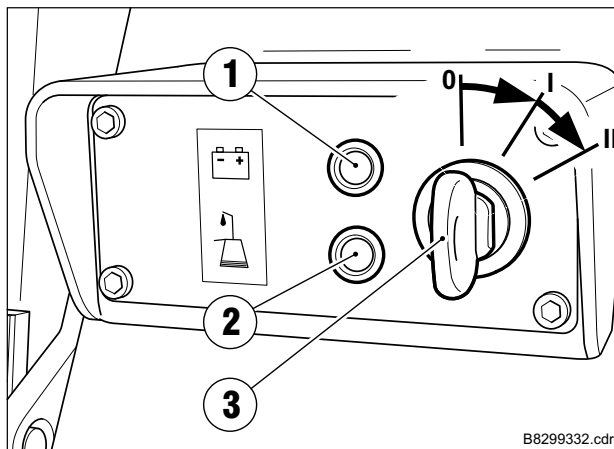

The oil pressure indicator (2) and charge indicator (1) serve for monitoring the oil pressure and function of the alternator.

After switching on the ignition (3) (position «I»), both indicators will flash twice, the charge indicator will subsequently extinguish and the oil pressure indicator will show a steady light for about 30 seconds. The control will subsequently disconnect the power supply.



If starting is not continued within 10 seconds, the procedure must be repeated.

Important

3.5.2 Starting the Engine



Important

The load indicator light (2) monitors the functioning of the alternator. It illuminates when the Engine stopped in the ignition on (position «I») and must go out when Engine runs.

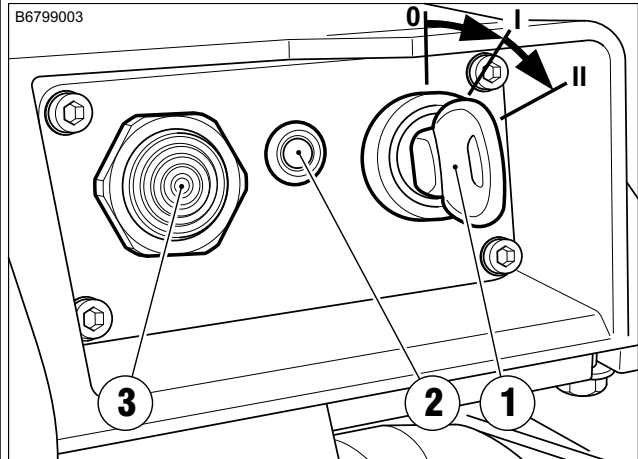

- Set the engine speed lever to full load.
- Machines with emergency-stop-connection: Press emergency-stop-connection.
- Insert the ignition key (1) and turn to «I»; the charge indicator (2) lights up and a horn* (3) sounds.
- Turn the ignition key (1) to «II».

*APH 5020 / 5030 / 6020 / 6530

If the engine starts,

- release the ignition key (1) and
- set the engine speed lever to idle.
- Allow the engine to run for 1-2 minutes in order to warm up.



Attention

Only operate the starter with a stationary engine.

Do not operate the starter for more than 20 – 30 seconds.

Immediately release the ignition key when the engine runs.

Wait for 30 seconds before trying again.

Never turn the key to the «0» position when the engine is running. The regulator can be destroyed and the battery will not charge !

3.5.3 Hand start



Machines with electrical starter: Never hand start with a disconnected battery, this leads to immediate destruction of the regulator.

- Set the engine speed control lever to full load.
- Machines with emergency-stop-connection : Press emergency-stop-connection.
- Machines with electrical start : Turn ignition key via position I.

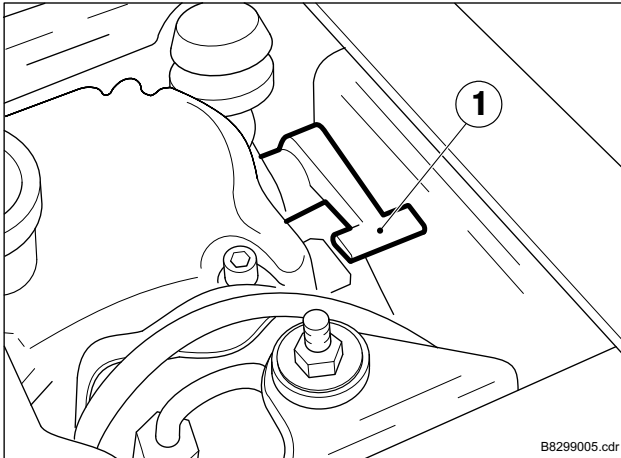

- Move the decompressor (1) lever until it stops in start position.

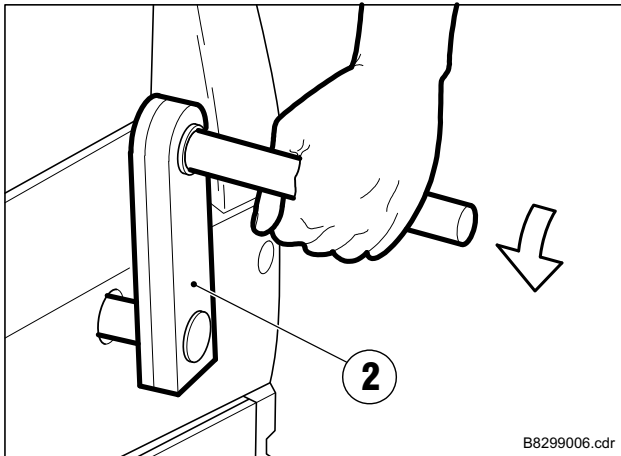

- Insert the starting crank (2) and turn it with increasing speed.

After starting of the engine,

- release ignition key.
- Set the speed lever to idle.
- Allow the engine to run for 2-3 minutes in order to warm up.
- By misfire ignition return the decompressor lever to its initial position and repeat steps 1-5.

3.5.4 Switching-off the engine



Do not switch-off the engine by full load and don't use the decompressor lever.

- Allow the engine to run a short while on idling.
- Set the speed lever to stop.

Additionally by electrostart:

- Turn the ignition key to «0» position. (The indicator lamps should go out.)



The horn will sound if the ignition key is not returned to the «0» position; a risk of total battery discharge exists.

- Remove the key.



At the end of a working day or a break protect the key from unauthorised access.

3. Operation

3.5.5 Automatic engine cut-off (APH 5020 – 6530)

Machines are equipped with a safety engine cut-off. The engine switches-off automatically if

- the oil pressure is too low
- the film of lubrication oil is unstable as a result of
 - excessively high oil temperature
 - incorrect basic viscosity
 - dilution of the oil by fuel or water
- the lubricating oil filter is blocked
- a leakage in the oil relief valve
- leakages in pipes and seals
- the oil pumps and bearings are worn.



If the oil level is too low or the machine is tilted too much, it can lead to an admixture of air and thus to a loss of viscosity.

If the engine cuts-out because the supply of lubricating oil is insufficient, proceed as follows :

- Locate the fault and have it rectified.

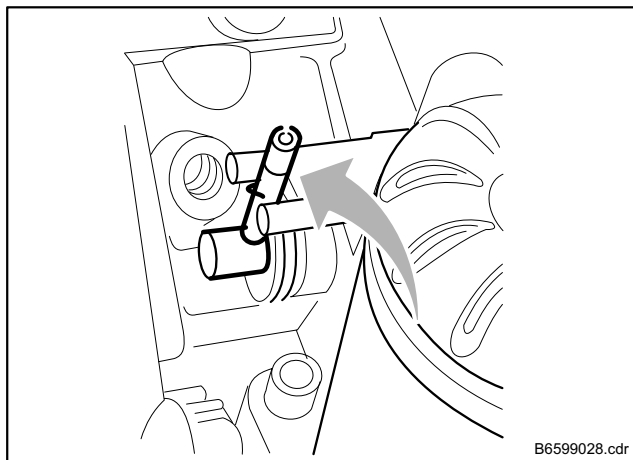

- Press the lever few seconds.
- Start the engine.

3.5.6 Air filter maintenance indicator

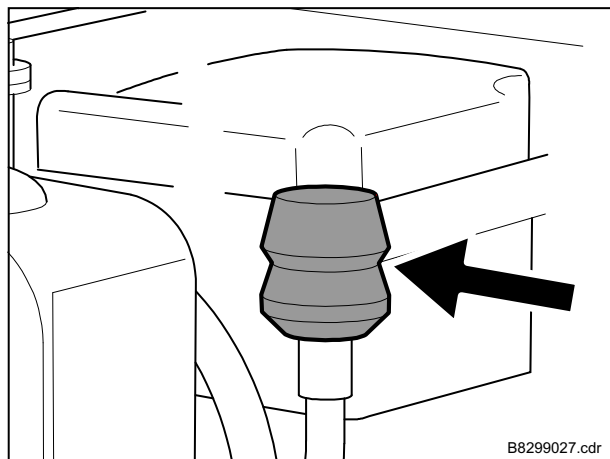

The motors are equipped with a maintenance indicator for air filters. In case of pollution of the filter element the rubber bellow contracts by underpressure.

In this case, switch-off the motor and clean or replace the air-filter.

3.6 Operation



Important

Under adverse conditions start-up of the exciter may be impeded. Then the engine cannot reach its nominal RPM. This can be remedied by activating the drive lever (2) several times.

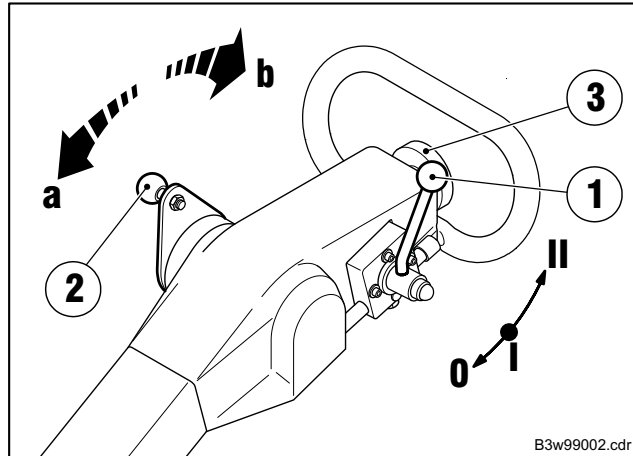

- Set the speed lever (1) in full load direction.



Attention

To avoid coupling damages, take care that the motor speed of the machines with centrifugal clutches are clearly above or resp. below the starting speed (about 1200 rpm).

The motor has to cut-off by long working breaks; long idle-runnings can take to great motor damages.

- Adjust the drive direction and speed at the drive lever (2).
- Guide and steer the machine at the tow bar; the operator should go alongside the tow bar.



Important

For compaction of paving stones, it is recommended to use Vulkollan plates and protective brackets (special accessories) to prevent damages to the compaction material and to the machine.

If the machine is used without protective bracket, the threaded fastenings in the base plate must be sealed with the supplied screw plugs.

3. Operation

3.7 Electronic dead man's control (option)

In this section only the operating and safety instructions are described which diverge from the Standard – Operating instructions. Otherwise the standard operating instructions obviously apply.

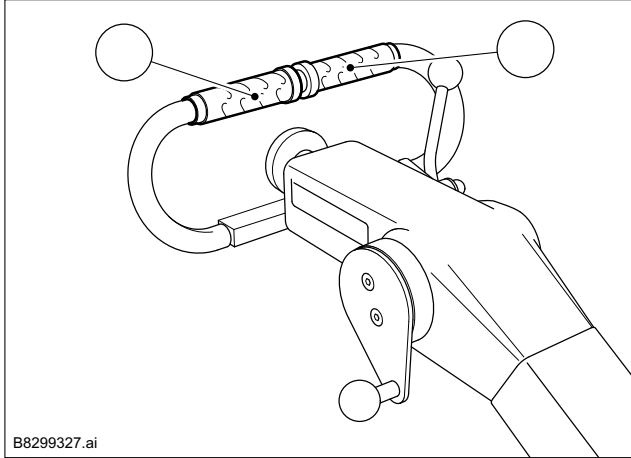

Machines with an emergency off switch can be supplied as an option with an electronic dead man's control. The drive is controlled over an electronic component and integrated touch sensors in the handles (sensoGRIP)(1).



It is forbidden to make any changes to the system. Deliberate or unintentional changes implemented on the handle, the electronics or the feeder cables can lead to a system break-down and with that endanger life and health.

Prior to every start-up the system must be examined for damaged cables and/or parts. Damaged parts must be exchanged immediately. The machine may not be taken into operation with any damaged parts.

Examine the gear switch for correct functionality after starting up the machine by checking the shut-down function by releasing the handle.

If, during the functionality test or machines operations the machine does not shut-down correctly then a continuation of operation may under no circumstances be sustained and a visit to the Ammann specialist workshop must take place immediately.

Despite the installation of a dead man's control unit a remaining danger still exists for the operator and other persons when working with the machine. For this reason always operate the machine with caution and consciousness of this remaining danger.

3.7.1 Operation

- Starting the motor (Section 3.5.2).

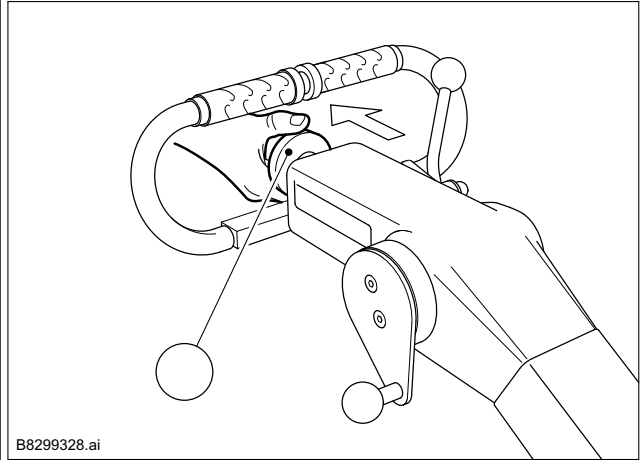

- Pull emergency off switch (2).

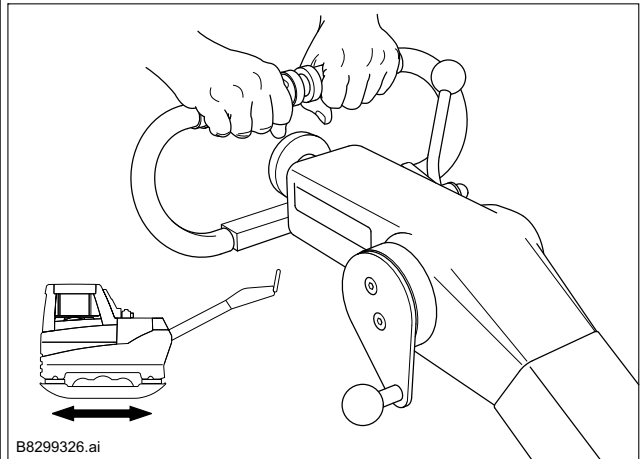

- Hold the handle (1) tightly; the machine will drive off in the set direction of drive.

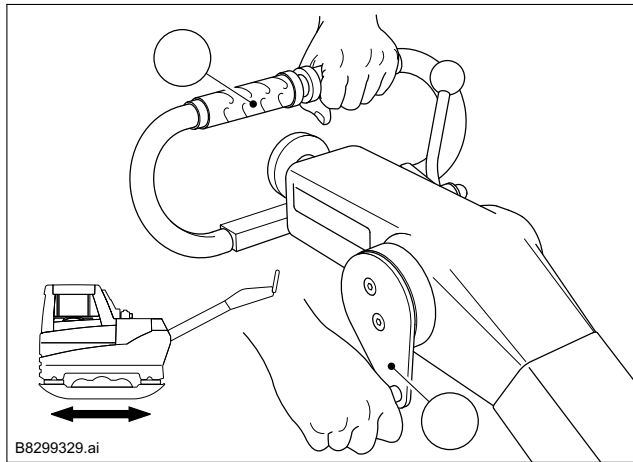

- Adjust direction of drive and speed with the drive lever (3); one hand must remain on the handle (1).

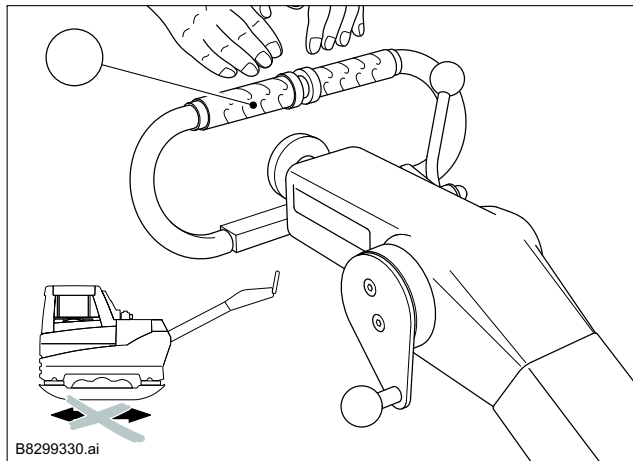

- If both handles (1) are released then the machine will come to a stand-still after a short over travel time period. If one of the handles is touched again then the machine will continue to drive in the previously selected direction of drive and speed.



The machine facilitates over a short over travel path. This must be taken into consideration when working with the machine.

It is absolutely necessary to press the emergency off switch inwards when taking a work break or at the end of the working period so that any unintentional driving off by the machine is prevented

4. ACEecon system

4.1 General

4.1.1 Description

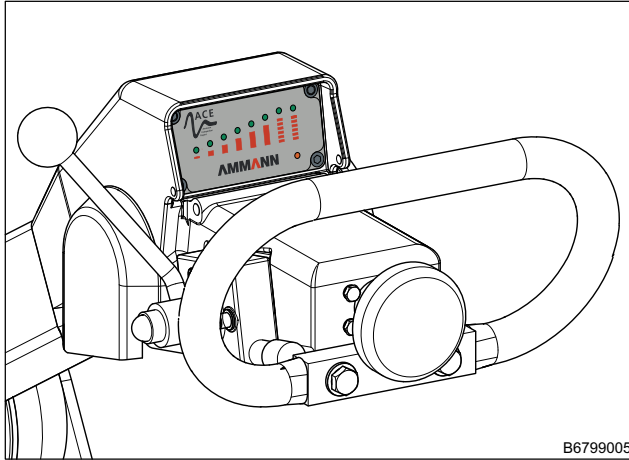

With the ACEecon system¹⁾ it is possible to perform comprehensive compression checks. For this, the soil rigidity is determined. An integrated sensor measures the reaction of the ground to the vibrating base plate. An LED display within the operator's range of vision continually shows the measurement value.

This inspection capability provides the user with several advantages, for example

- Always check whether compression progress is being made and whether the final density has been reached.
- Flawed areas in the compression can be found and recompacted.
- Over-compression, and material loosening and destruction can be prevented.
- Superfluous passes or vibrating on surfaces already compacted are avoided. That means more efficient, sparing use of the machine.

4.1.2 Function

The ACEecon system consists of a control/display panel, and an acceleration sensor on the base plate.

The integrated sensor converts acceleration of the base plate to voltage signals. These are transmitted to the controls. There the compression parameters are calculated and shown visually on the control/display panel.

4.1.3 Operation

The ACEecon system is especially suitable for loose ground with little fine material.

The degree and quality of compression depend on the existing soil conditions. If, despite an adequate number of passes, the maximum degree of compression is not shown, check the soil for its suitability for compression and, if necessary take measures to improve compression. Due to varying soil rigidity, the maximum value cannot be achieved in every case.

4.2 Operation

The various operating statuses are shown on the control panel as follows:

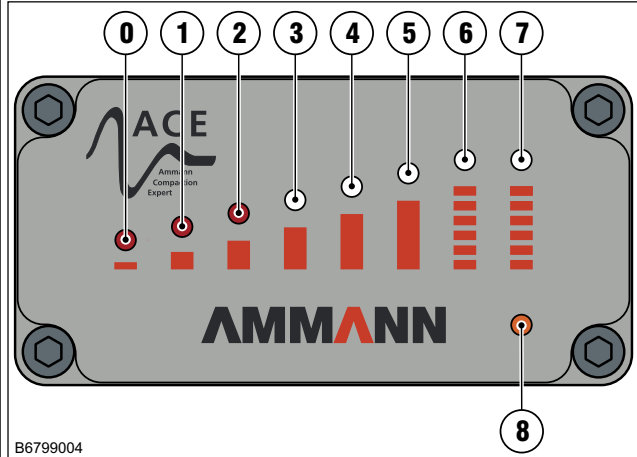

- The system starts automatically when the machine is started. Next, the system initializes:
 - The status LED (8) blinks; the LEDs (0-7) light up in a row from 0 to 7 and then go back off.
- After successful initialization, the status LED (8) glows. The system is now ready to operate.
- The relative compression value is shown by the LEDs as follows. The number of glowing LEDs symbolically represents the increasing soil compression.

VG	LED							
	0	1	2	3	4	5	6	7
0 – 19 %	●							
20 – 40 %	●	●						
41 – 60 %	●	●	●					
61 – 80 %	●	●	●	●				
81 – 100 %	●	●	●	●	●			
101 – 120 %	●	●	●	●	●	●		
121 – 140 %	●	●	●	●	●	●	●	
141 – 150 %	●	●	●	●	●	●	●	●

● → red

VG → Degree of compression



Correct measurement values can only be achieved by driving forward and backwards at maximum speed.

- If the status LED glows, and the 0 LED blinks, the vibration frequency is too high or too low. No measurement value can be calculated.
- If the 0 LED glows, and the status LED gives off a blink signal, the measuring system is malfunctioning. In this case, contact Ammann service.

¹⁾Optional equipment

5.1 Loading and transportation



Danger

Only use sufficiently strong and secure loading ramps when loading.

Check the contact points (frame, lifting rings) before use for damage and wear. Immediately replace damaged parts.

Secure the machine against rolling or slipping off and against tipping over.

Ensure that no persons will be endangered.

When loading, lashing down and lifting the machine always use the provided lifting points.

Persons are in danger, if they

- go near swinging loads or
- stand under swinging loads

After loading lock the tow bar.

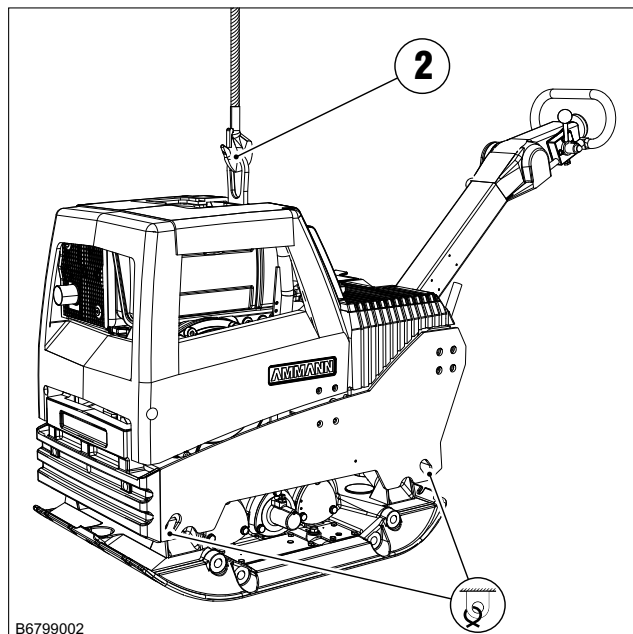

B6799002

After loading, the machine has to be attached in place (1).

Use the centre-of-gravity suspension point (2) in order to lift the machine.

6. Maintenance

6.1 General notes

Careful maintenance:

- ⇨ increased service life
- ⇨ increased function security
- ⇨ reduced downtimes
- ⇨ increased reliability
- ⇨ reduced repair costs

- Observe the safety regulations!
- Maintenance works should only be carried out when the engine is shut off.
- The engine and machine should be cleaned thoroughly before carrying out maintenance work.
- Park the machine on a flat surface and secure it against rolling away and slipping.
- Ensure that operating materials and replaced parts are disposed of safely and in an environmentally - friendly way.

- Before commencing work on any electrical equipment, disconnect the battery and cover it with insulating materials.
- Do not exchange «PLUS» and «MINUS» poles on the battery.
- It is essential that short-circuits be prevented in cables carrying current.
- Before welding works on the machine put-off all connections and battery cables.
- Burn-out lightbulbs in indicator lamps should be replaced immediately.
- When cleaning the machine with a high-pressure water jet, do not spray the electrical components directly.
- After washing the components, blow-dry them with compressed air in order to prevent surface leakage current and corrosion.

6.2 Maintenance schedule

Works	Intervals							
	daily	20 h	50 h	100 h	250 h	500 h	1000 h	if necessary
Clean machine	●							
Check engine oil level ¹⁾	●							
Change engine oil ¹⁾		● ³⁾			●			
Change engine oil filter ¹⁾		● ³⁾			●			
Check air filter ¹⁾	●							
Change air filter element ¹⁾			●			●		
Check suction air intake ¹⁾	●							
Drain water (Fuel tank) ¹⁾		●						
Change fuel filter ¹⁾							●	
Check valve clearance ¹⁾		● ³⁾			●			
Exciter: Check oil level			●					
Exciter: Change oil ²⁾				● ³⁾	●			
Check hydraulic oil level	●							
Change hydraulic oil ²⁾						● ³⁾	●	
Change return filter element ²⁾		● ³⁾					●	
Change ventilation filter ²⁾						● ³⁾	●	
Clean suction filter ²⁾						● ³⁾	●	
Check the hydraulic hose lines				●				
Check rubber buffers				●				
Check screwed connections for tightness		● ³⁾		●				

¹⁾See engine operating manual
²⁾minimum once a year
³⁾for the first time

6.3 Lubrication schedule

Lubricating point	Quantity [l]	Changing intervals [operating hours]	Lubricant	Order No.
1. Engine (incl. oil filter)				
APH 5020 / 5030	1,4 (1,5)	250	Engine oil API SG-CE SAE 10W40	2-806 01 100
APH 6020 / 6530	1,8 (1,9)			
APH 100-20				
2. Exciter				
APH 5020	1,0	250 or annually	Gear oil in acc. with JDM J 20 C	2-806 01 110
APH 5030				
APH 6020	1,8			
APH 6530	1,8			
APH 100-20	2,0			
3. Hydraulic				
APH 5020 / 5030	19,0	first time after 500, then every 1000 or annually	Hydraulic oil HVLP 46	2-806 01 070
APH 6020 / 6530	20,0			
APH 100-20	27,0			
4. Return filter element				
APH 5020 / 5030		first time after 20, then with each hydr. oil change		2-801 99 100
APH 6020 / 6530 / 100-20				2-801 99 160
5. Ventilation filter				
APH 5020 / 5030 / 6020 / 6530 / 100-20		with each hydr. oil change		2-801 99 153
6. Clean suction filter				
APH 5020 / 5030 / 6020 / 6530		with each hydr. oil change		2-802 26 230
APH 100-20				2-802 26 327

6.4 Alternative lubrication schedule

	Engine oil API SG-CE SAE 10W40	Gear oil in acc. with JDM J 20 C	Special hydro-oil ISO-VG 32	Hydr.-oil HVLP 46	ATF – oil
ARAL	Extra Turboral SAE 10W40	Fluid HGS	Vitam GF 32	Vitam HF 46	ATF 22
BP	Vanellus C6 Global Plus SAE 10W40	Hydraulik TF-JD	Energol HLP-HM 32	Bartran HV 46	Autran MBX
CASTROL	Tecton SAE 10W40	Agri Trans Plus	Hyspin SP 32	Hyspin AVH-M 46	TQ-D
ESSO	Ultra 10W40	Torque Fluid 56	Univis N 32	Univis N 46	ATF 21611 II-D
FINA	a. Kappa FE b. Kappa Turbo DI	Transfluid AS	a. Hydran TSX 32 b. Biohydran TMP 32 ²⁾	—	Finamatic II D
FUCHS	Titan Unic MC	Agrifarm UTTO MP	a. Renolin ZAF 520 b. Plantohyd 32 S ²⁾	Renolin B 46 HVI	Titan ATF 3000
KLEENOIL PANOLIN	—	—	Panolin HLP Synth 32 ²⁾	—	—
MOBIL	a. Delvac SHC b. Mobil Super M 10W40 c. Mobil Super S 10W40 ¹⁾	a. Mobilfluid 424 b. Mobilfluid 426	Mobil DTE 24	Univis N 46	ATF 220
SHELL	Engine Oil DG 1040	Donax TD	Tellus T32	Tellus T 46	a. Donax TA b. Donax TX
TOTAL	Rubia Polytrafic 10W-40	Transmission MP	Azolla ZS 32	Equivis ZS 46	Fluide ATX

¹⁾Semi-synthetic light-duty oils

²⁾Biological multi-purpose hydraulic-oils;

The miscibility and compatibility with mineral oil based hydraulic oils and biological hydraulic-oils should be examined in the individual case.
The residual mineral oil content should be reduced acc. to VDMA specification 24 569.

6. Maintenance

6.5 Maintenance work on the engine



Only the maintenance work which has to be performed daily is included in the Operating Manual. Please refer to the engine Operating Manual and to the maintenance instructions and intervals listed therein.

6.5.1 Overview

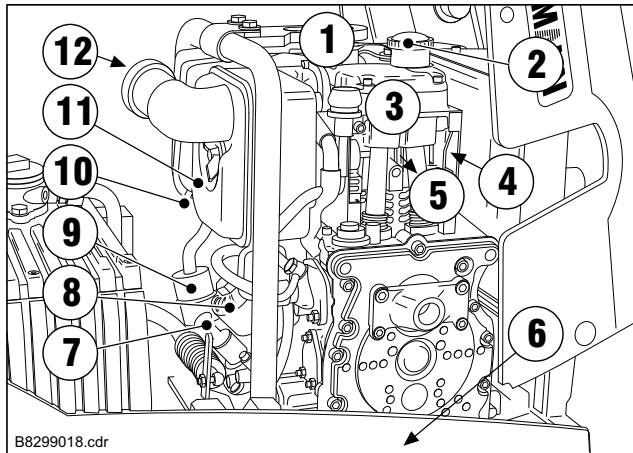

- 1 Fuel filling socket
- 2 Oil filling socket
- 3 Air filter maintenance indicator
- 4 Cooling air intake
- 5 Cooling air outlet
- 6 Oil outlet
- 7 Oil measuring dip
- 8 Oil filter
- 9 Fuel filter
- 10 Water outlet, fuel tank
- 11 Air filter
- 12 Suction orifice - Combustion air

6.5.2 Filling-up with fuel



Only top-up by stationary motor.

No open fire.

Do not smoke.

Do not fill-up in closed rooms.

Do not inhale petrol fumes.

Collect spilt fuel in a suitable container and prevent spillage entering the soil.

- Clean around the fuel filler socket (1).
- Open the fuel filler socket and
- Visually check the fuel level.
- Top-up if necessary. All diesel oils sold as fuel and complying with the following minimum specification can be used: EN 590 or DIN 51601 - DK or BS 2869 A1 / A2 or ASTM D 975 - 1D / 2D
- Close the tank tightly.

6.5.3 Check engine oil level



Immediately replace damaged seals.



Collect old oil and dispose of it in an environment friendly manner.

Do not permit oil to run onto the floor into the drains.

- Park the machine horizontally.
- Clean the area around the measuring dip.
- Draw out measuring dip(7), wipe-off with clean, lintfree cloth.
- Insert measuring dip again until the stop.
- Draw out measuring dip again and check oil level.
- If necessary, refill oil until upper marking.
- Clean area around filler socket.
- Open the filler socket (2).
- Fill-in required oil quantity.
- Secure oil filling socket.
- Insert measuring dip.
- Allow the motor to run for approx. 1 min. and check oil level; complete if necessary.

6.5.4 Check area around combustion air and cooling air system

Check intake opening for combustion air and cooling air intakes. Remove coarse obstructions such as leaves, stones and earth.

6.5.5 Draining off water (fuel tank)

The fuel tank must be checked once a week for accumulations of water in order to prevent water from penetrating into the sensitive injection system.

- Unscrew screw (10) to last turn on the thread.
- Collect drops which flow out in a clear container.
- Determine by visual inspection whether water is draining out (water settles to the bottom of the container).
- As soon as fuel flows out, close the screw again.

6.5.6 Cleaning the air filter element

- Remove air-cover
- Carefully pull out filter element.
- Use a jet of dry compressed air (max. 5 bar) to blow through the filter element from the inside outwards, moving it up and down at the same time, until no further dust emerges.
- Tilt the filter element and hold it against the light (or shine a light through it) to trace any cracks or other damage.



Change filter element:

- If the filter element or sealing ring is damaged
- After cleaning twice
- If there are soot-containing deposits
- If moist or oily
- When engine performance reduces or
- the colour of the exhaust gas changes

Never operate the engine without air filter element

- Clean air cover and -housing with lintfree cloth.
- Carefully pull in the filter element.
- Fit-up the cover.

6.6 Machine maintenance

6.6.1 Cleaning

Clean the machine on a daily basis.



After cleaning

- all cables, hoses, connections and connectors are to be checked for leakage, holed connections, chafing points and other damage.
- Detected faults are to be eliminated immediately.

No combustible or aggressive materials are to be used for cleaning.

6.6.2 Tightening torques

Ø	8.8		10.9		12.9	
	Nm	ft lb	Nm	ft lb	Nm	ft lb
M 4	3	2	4,4	3	5	4
M 5	6	4	8,7	6	10	7
M 6	10	7	15	11	18	13
M 8	25	18	36	26	43	31
M 10	49	36	72	53	84	61
M 12	85	62	125	92	145	106
M 14	135	99	200	147	235	173
M 16	210	154	310	228	365	269
M 18	300	221	430	317	500	368
M 20	425	313	610	449	710	523
M 22	580	427	830	612	970	715
M 24	730	538	1050	774	1220	899

TAB01001.cdr

Strength classes for screws with untreated, non-lubricated surface.

The values result in 90% utilisation of the apparent yielding point at a friction coefficient $\mu = 0.14$.

Tightening torques are checked for correctness using torque wrenches.

When using lubricant MoS2, the specified values do not apply.



Renew self-locking nuts after each removal.

6.6.3 Screwed connections

With vibrating machines, it is important to check the screwed connections for tightness at regular intervals. Observe tightening torques.

6.6.4 Changing rubber buffers

Inspect the rubber buffers for cracks and chipping as well as tightness and immediately replace if damaged.

6.6.5 Exciter: Oil change / Oil level



Change oil when it is warm.

The venting screw (3) must always first be unscrewed when checking the oil level or changing the oil.

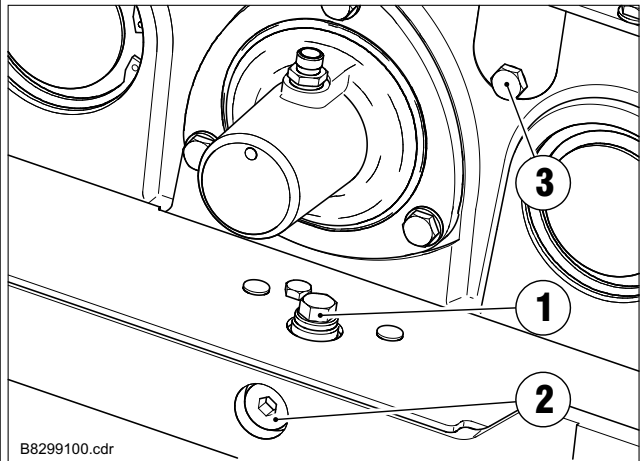

- Unscrew venting screw (3), oil filling plug/dipstick (1) and oil drain plug (2).



Care is to be taken with the draining of hot oil : danger of scalding!

- Drain-off old oil.



Collect oil which has run out or overflowed and dispose it in an environment friendly manner.

- Screw-in oil drain screw (2).
- Fill-in new oil through the oil fill hole (1). See lubrication plan for quantity and quality.

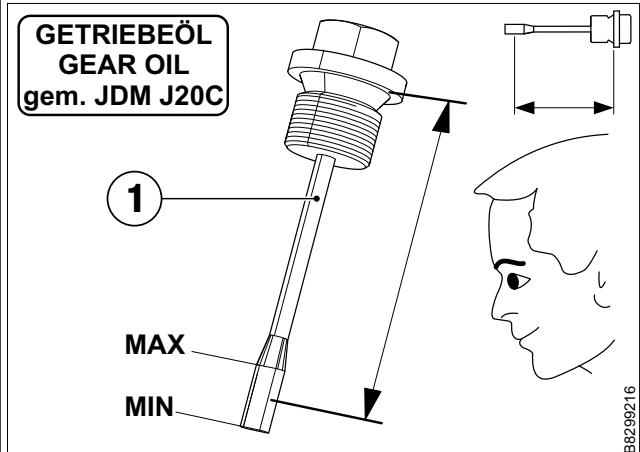

When the dipstick is screwed in, the optimal oil level is between the «MIN» and «MAX» markings.

- Replace oil filling plug/dipstick (1) and venting screw (3).
- Unscrew oil filling plug/dipstick (1), check the oil level again and top up with oil if necessary.
- Replace oil filling plug/dipstick (1).

6. Maintenance

6.7 Hydraulic



Before working on the hydraulic make the system pressureless.

Attention

Carry out the change of hydraulic oil while it is still warm in accordance to the lubrication plan and the lubrication table.

Do not start the motor while the hydraulic oil is draining under any circumstance.

Immediately replace any damaged seals.

Change the return filter element and the air filter with each change of hydraulic oil.

Change the hydraulic oil also after each major repair on the hydraulic unit.



Environment

Collect the drained-off hydraulic oil and dispose it in an environment friendly manner.

6.7.1 Hydraulic hose lines

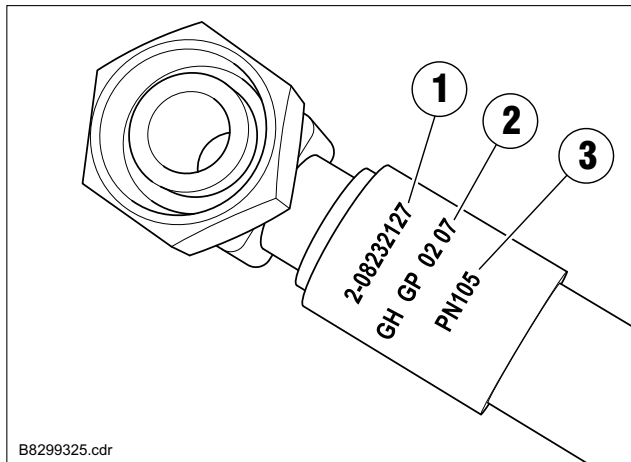

B8299325.cdr

- 1 Ammann Article No.
- 2 Manufacturer/Month and year of manufacture
- 3 Max. operating pressure

The function of hydraulic hose lines must be tested at regular intervals (minimum once a year) by an expert (with a knowledge of hydraulics).

Hose lines must immediately be replaced in the following instances:

- Damage to the outer layer to the inner lining (abrasion marks, cracks, cuts, etc.).
- Brittleness of the outer layer (cracking of hose covering).
- Unnatural deformations of the hose line. This applies to both a pressureless and pressurised condition (e.g. layer separation, blister formation, crushed areas, kinks).
- Leaks.
- Damage or deformation of hose fittings (impaired sealing function).
- Hose slips out of the fitting.
- Corrosion of fitting (degrading of function and strength).
- Improper installation.
- Use beyond the expiry date of max. 6 years.

6.7.2 Check the hydraulic oil level

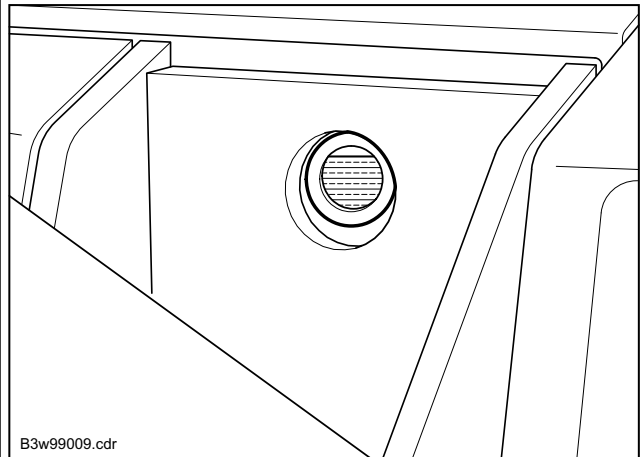

B3w99009.cdr

- Check the oil level through the oil gauge glass.
- If necessary top up the oil level up to the upper area of the glass.



Attention

If hydraulic oil is missing by the daily hydraulic oil level control, the components, hoses and connections have to be checked immediately.

6.7.3 Changing the return filter element

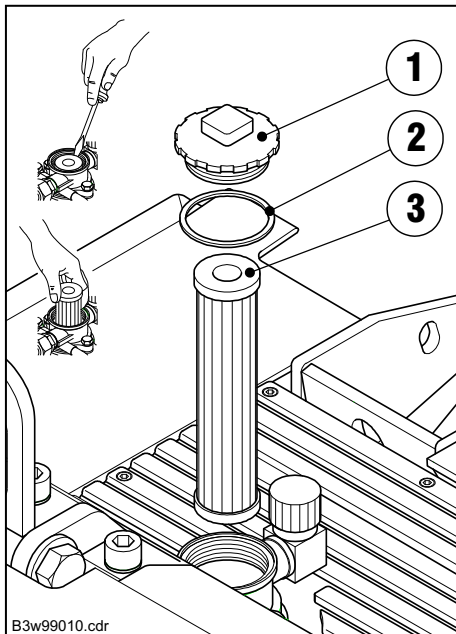

- Loosen the filter cover (1) with a screwdriver (SW 27) and unscrew. Permit the oil in the filter housing to run through the filter element (3) and into the tank.
- Lift the filter element with a screwdriver and withdraw it together with the filter head from the head section.
- Remove the filter element by turning and pulling it at the same time from the filter head and dispose it in an environment friendly manner.
- Drain the remaining oil from the filter head into an old oil container and dispose it in an environment friendly manner.
- Clean the filter head with washing petrol or diesel oil.
- Check the surface seal (2) and O-ring and if necessary change them.
- Insert a new filter element in the filter head.
- Install the filter head with filter element into the head part; taking care with the O-ring.
- Screw on the filter cover and pull tighten with hand, check for a trouble-free location of the surface seal.
- Take a test-run if the filter is tight.

6.7.4 Hydraulic oil change

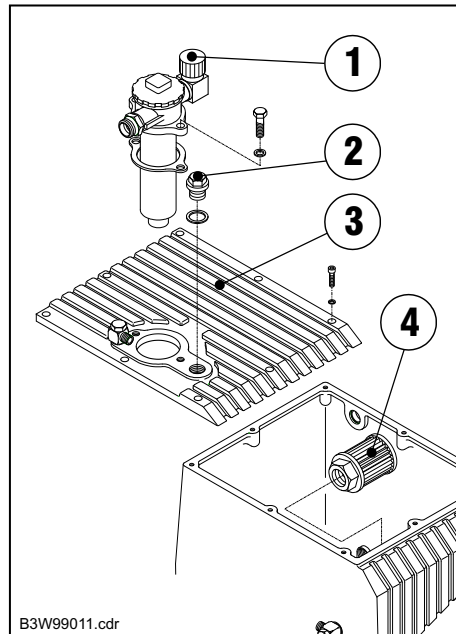

Care is to be taken with the draining of hot oil : danger of scalding !

Wear protection spectacles - danger of eye injury!

- Open the oil fill screw (2) and the oil drain screw, drain off the oil and dispose it in an environment friendly manner.
- Remove the cover (3).
- Release the input filter (4) in the tank and unscrew.
- Wash out the intake filter in cold cleaner or washing petrol and blow out with compressed air.
- Thoroughly clean the hydraulic tank.
- Insert the intake filter.
- Carefully remove the seal remains from the seal surfaces.
- Fit new sealing compound.
- Fit the hydraulic tank cover
- Screw-in the oil drain screw, if necessary use a new seal.
- Replace the air filter (1) taking care with the O-ring.
- Fill-in new oil

For oil quantity and type see the lubrication plan.

- Screw in the oil fill screw and pull tighten (if necessary use a new seal).
- Take a test run, check the oil level and if necessary top up.

7. Battery



The instructions on the battery and in



Wear eye protection during all operations.



Keep children away from acid, batteries, and chargers.



Explosion hazard :

- While charging batteries, a highly explosive oxyhydrogen mixture develops, therefore:



Fire, sparks, open light, and smoking forbidden!

- Avoid spark creation when operating with cables and electric devices!
- Avoid short-circuits!
- Avoid electro-static discharges.



Corrosive hazard

Battery acid is highly corrosive, therefore:

- Wear protective gloves and eye protection during all operations on the battery.
- Do not tilt battery, acid may leak from the degassing openings.



First aid

- Rinse out acid splashed in the eyes immediately for several minutes with clear water. Then consult a doctor immediately.
- Neutralize acid splashes on skin or clothing immediately with acid neutralizer (soda) or soap suds and rinse with plenty of water.
- If acid has been drunk, immediately consult a doctor!



Warning note

- Do not place batteries in direct sunlight without protection (box becomes crumbling).
- Discharged batteries can freeze up (freezing point of acid of fully charged battery -70°C, at 50% state of charge)

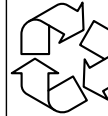

Disposal

- Hand in old batteries at a collection point.
- The notes listed under point 1 are to be followed during transport.
- Never dispose of old batteries as domestic waste!
- Transport damaged batteries in suitable containers (acid leakage).

7.0.1 Storage and transport

- Unfilled batteries do not require any maintenance.
- Always store wet charged batteries in a cool place (but not in a refrigerator or freezer).
- Regularly check the state of charge or use charge maintaining devices.
- Recharge wet charged batteries at an acid density of 1.21 kg/l or 12.3 V open circuit voltage or after request for charge by the optical state of charge indicator at the latest (see point 7.0.4).
- Wet charged batteries are to be transported and stored upright, protected against tipping over, and protected against short-circuit, since acid may escape otherwise.

7.0.2 Commissioning

- Regard safety regulations.
- Wet charged delivered batteries are ready for use. Only install sufficiently charged batteries, minimum 12.50 V open circuit voltage.
- Remove sealing plugs. Fill the individual cells of the battery with sulphuric acid according to DIN IEC60933-1 of density 1.28 kg/l up to the maximum acid level.
- Allow battery to stand for 15 minutes, tilt slightly several times, and refill acid if necessary.
- Tightly screw in or press in the sealing plugs.
- Wipe off any acid splashes.
- In case the battery does not show a sufficient starting performance due to too low temperature or unfavourable storage conditions, the battery needs to be recharged (see point 7.0.4).

7.0.3 Installation in and removal

- Prior to removing the battery, switch off the engine and all electric consumers.
- When removing the battery, first disconnect the negative terminal (-), then disconnect the positive terminal (+).
- Clean battery terminal and terminal clamps and treat them with acid-free grease.
- Clamp battery tightly (use original fastening).
- Only remove the protection cover from the positive terminal in the vehicle when connecting the battery and place it on the terminal of the replaced battery in order to avoid short-circuits and spark creation.
- When installing the battery, first connect the positive terminal (+), then connect the negative terminal (-).
- Assure tight fit of the terminal clamps.
- Take over accessories such as terminal covers, elbow piece, tube connection, closing plugs and terminal clamp holders (where available) from the replaced battery and connect them the same way.
- Keep at least one degassing opening unclosed, otherwise explosion hazard (this also concerns the return transport of the old battery).

7.0.4 External charging

- Read and follow manual of the charger manufacturer.
- Check electrolyte level before charging and balance it where necessary (see point 7.0.5 – maintenance)
- Only charge the battery with suitable, voltage regulated chargers with the same nominal voltage, otherwise the battery has to be disconnected/removed. Recommendation:
Charging current: 1/10 Ampere of the battery capacity Ah
Charging voltage: 14,4 V
- Never charge frozen batteries or batteries with a temperature higher than 45°C.
- Connect the positive terminal (+) of the battery with the positive terminal (+) of the charger and the negative terminal (-) of the battery with the negative terminal (-) of the charger.
- Only switch on the charger after connecting it to the battery.
- Only switch off the charger after charging has been completed.
- Interrupt charging if the acid temperature exceeds 55°C.
- In case the battery becomes hot or acid leaks, the charging must be interrupted!
- The battery is fully charged if:
 - Current and voltage remain constant with voltage regulated chargers.
 - The charging voltage does not rise anymore within two hours with a current regulated charger. The automatic charger switches off or switches over to maintain charge.
- Ensure good ventilation during charging.

7.0.5 Maintenance

- Keep the battery surface clean and dry, only clean with damp or antistatic cloth.
- Protect terminals/connection clamps against corrosion (as described under point 7.0.3).
- Control electrolyte level (regard inner or outer marking on the box or optical acid level indicator in the lid).
- If necessary, refill demineralised or distilled water according to DIN IEC 60933-3... up to the maximum acid level (never refill acid, foreign matters or so-called optimizers).
- In case of high electrolyte loss, consult a garage.
- In case of insufficient starting performance, check battery and possibly recharge it (see point 7.0.4).

7.0.6 Jump Starting

- Only use standardized jump start cables (e.g. according to DIN 72 553).
- Regard instructions of the jump start cable manufacturer.
- Only use batteries of the same nominal voltage.
- Switch off the engine of the giving vehicle (1).
- Connect jump start cable to the positive terminal (+) of the donor battery \hat{E} and to the positive terminal (+) of the receiving battery \hat{E} or to the positive (+) vehicle connection terminal.
- Only then connect the jump start cable to the negative terminal (-) of the donating battery \hat{I} and to a sturdy, blank mass in the receiving vehicle or to the negative (-) jump start point \hat{I} (Do not use the negative terminal of the receiving battery as a point of connection).

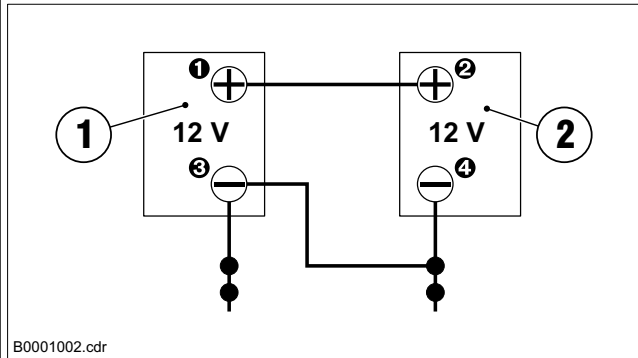

- Start receiving vehicle (2).
- In case the first attempt to jump start the vehicle fails, the donating vehicle can be started BEFORE the second jump start try.
- Disconnect the jump start cables in opposite order.

8. Troubleshooting

8.1 General information

- Observe the safety information
- Only qualified and authorised persons may carry out repair work
- In case of faults, the operating and maintenance instructions must be referred to for correct operation and maintenance.

- If the cause of the fault cannot be located or remedied, an authorised Ammann Service Centre should be contacted.
- Always first check the most likely causes (fuses, LEDs, etc.)

8.2 Fault table

Possible cause	Remedy	Remarks
Engine does not start		
Speed control lever in «STOP»-position	Set lever to «START»-position	
No fuel reaching injection pump		
– Tank run dry	Add fuel	
– Fuel filter blocked	Renew fuel filter	
– Defective feed pump	Function must be checked	
Oil pressure lost	Check engine oil level	Activate mechanical oil pressure monitor
Compression too low	Contact a HATZ-service station	
Engine stops by itself during regular operation		
Fuel supply is interrupted		
– Tank run dry	Add fuel	
– Fuel filter blocked	Renew fuel filter	
– Defective feed pump	Function must be checked	
Oil pressure lost	Check engine oil level	Activate mechanical oil pressure monitor
Mechanical defects	Contact a HATZ-service station	
Reduced engine performance		
Fuel supply is obstructed		
– Tank run dry	Add fuel	
– Fuel filter blocked	Renew fuel filter	
– Tank venting is inadequate	Ensure that tank is adequately vented	
– Leaks at pipes unions	Check threaded pipe unions	
Air cleaner blocked	Remove dirt from air cleaner	
Incorrect valve clearance	Adjust valve clearance	
Too much oil in engine	Drain off engine oil down to upper mark on dipstick	
Too much oil in exciter	Check exciter oil level	Contact a Ammann-service station
Default in hydraulic system	Contact a Ammann-service station	
Engine runs, machine does not move forward		
Centrifugal clutch lining worn	Replace linings and springs	
Too much oil in exciter	Check exciter oil level	Contact a Ammann-service station
Default in hydraulic system	Contact a Ammann-service station	